

## Book 4: Chapter 2

# Representation of Propositions in Terms of $x$ and $m$ , or of $y$ and $m$ .

Section 1. Representation of Propositions of Existence in terms of  $x$  and  $m$ , or of  $y$  and  $m$ .

Let us take, first, the Proposition “Some  $xm$  exist”.

[Note that the full meaning of this Proposition is (as explained at p. 12) “Some existing Things are  $xm$ -Things”.]

This tells us that there is at least one Thing in the Inner portion of the North Half; that is, that this Compartment is occupied. And this we can evidently represent by placing a Red Counter on the partition which divides it.

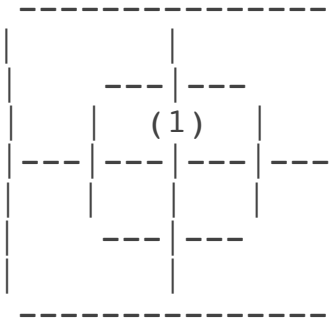

[In the “books” example, this Proposition would mean “Sound old bound books exist” (or “There are some old bound books”).]

Similarly we may represent the seven similar Propositions, “Some  $xm'$  exist”, “Some  $x'm$  exist”, “Some  $x'm'$  exist”, “Some  $ym$  exist”, “Some  $ym'$  exist”, “Some  $y'm$  exist”, and “Some  $y'm'$  exist”.

Let us take, next, the Proposition “No  $xm$  exist”.

This tells us that there is nothing in the Inner portion of the North Half; that is, that this Compartment is empty. And this we can represent by placing two Grey Counters in it, one in each Cell.

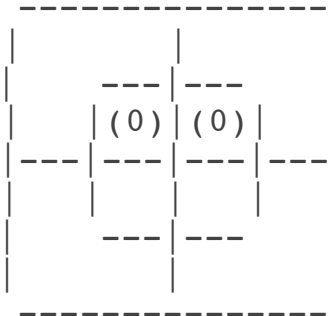

Similarly we may represent the seven similar Propositions in terms of x and m, or of y and m, viz. "No xm' exist", "No x'm exist", &c.

These sixteen Propositions of Existence are the only ones that we shall have to represent on this Diagram.

Section 2. Representation of Propositions of Relation in terms of x and m, or of y and m.

Let us take, first, the Pair of Converse Propositions

"Some x are m" = "Some m are x."

We know that each of these is equivalent to the Proposition of Existence "Some xm exist", which we already know how to represent.

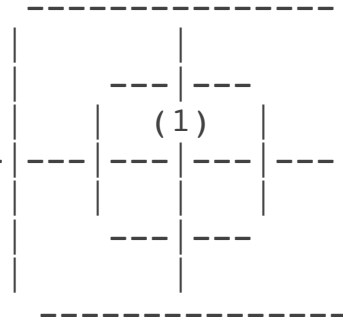

Similarly for the seven similar Pairs, in terms of x and m, or of y and m.

Let us take, next, the Pair of Converse Propositions

"No x are m" = "No m are x."

We know that each of these is equivalent to the Proposition of Existence "No xm exist", which we already know how to represent.

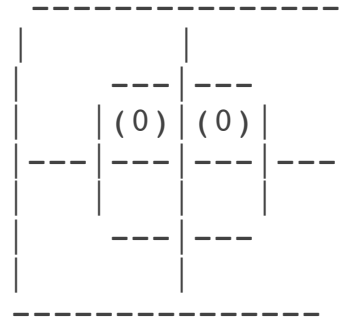

Similarly for the seven similar Pairs, in terms of x and m, or of y and m.

Let us take, next, the Proposition "All x are m."

We know (see p. 18) that this is a Double Proposition, and equivalent to the two Propositions "Some x are m" and "No x are m' ", each of which we already know how to represent.

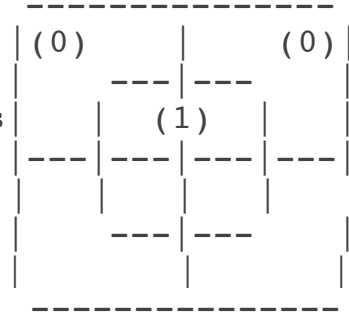

Similarly for the fifteen similar Propositions, in terms of x and m, or of y and m.

These thirty-two Propositions of Relation are the only ones that we shall have to represent on this Diagram.

The Reader should now get his genial friend to question him on the following four Tables.

The Victim should have nothing before him but a blank Tiliteral Diagram, a Red Counter, and 2 Grey ones, with which he is to represent the various Propositions named by the Inquisitor, e.g. "No y' are m", "Some xm' exist", &c., &c.

TABLE V.

	<p>Some xm exist                      =Some x are m                      =Some m are x</p> <hr/> <p>No xm exist                      =No x are m                      =No m are x</p>	
	<p>Some xm' exist                      =Some x are m'                      =Some m' are x</p> <hr/> <p>No xm' exist                      =No x are m'                      =No m' are x</p>	
	<p>Some x'm exist                      =Some x' are m                      =Some m are x'</p> <hr/> <p>No x'm exist                      =No x' are m                      =No m are x'</p>	
	<p>Some x'm' exist                      =Some x' are m'                      =Some m' are x'</p> <hr/> <p>No x'm' exist                      =No x' are m'                      =No m' are x'</p>	

TABLE VI.

	<p>Some <math>ym</math> exist                      =Some <math>y</math> are <math>m</math>                      =Some <math>m</math> are <math>y</math></p> <hr/> <p>No <math>ym</math> exist                      =No <math>y</math> are <math>m</math>                      =No <math>m</math> are <math>y</math></p>	
	<p>Some <math>ym'</math> exist                      =Some <math>y</math> are <math>m'</math>                      =Some <math>m'</math> are <math>y</math></p> <hr/> <p>No <math>ym'</math> exist                      =No <math>y</math> are <math>m'</math>                      =No <math>m'</math> are <math>y</math></p>	
	<p>Some <math>y'm</math> exist                      =Some <math>y'</math> are <math>m</math>                      =Some <math>m</math> are <math>y'</math></p> <hr/> <p>No <math>y'm</math> exist                      =No <math>y'</math> are <math>m</math>                      =No <math>m</math> are <math>y'</math></p>	
	<p>Some <math>y'm'</math> exist                      =Some <math>y'</math> are <math>m'</math>                      =Some <math>m'</math> are <math>y'</math></p> <hr/> <p>No <math>y'm'</math> exist                      =No <math>y'</math> are <math>m'</math>                      =No <math>m'</math> are <math>y'</math></p>	

TABLE VII.

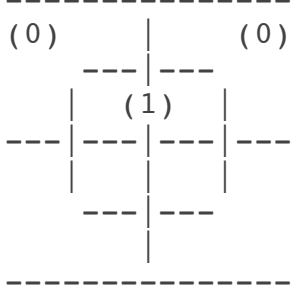
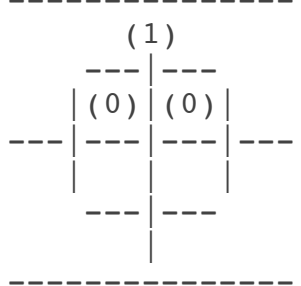
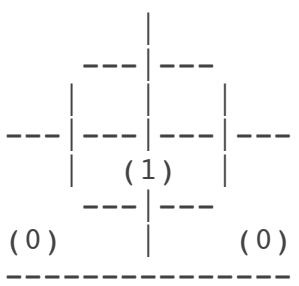
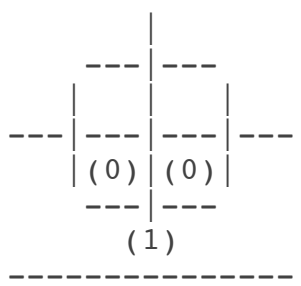
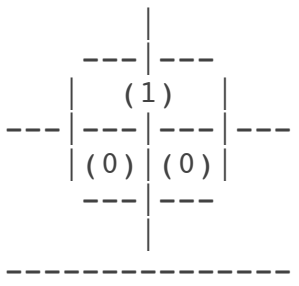
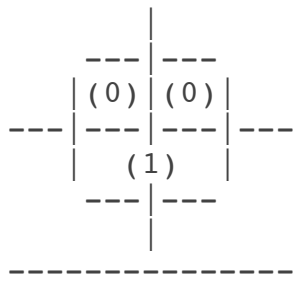
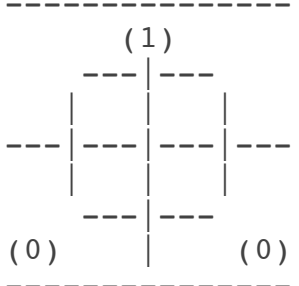
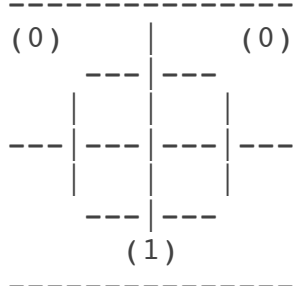
	<p>All x are m</p> <hr style="border: 0.5px dashed black;"/> <p>All x are m'</p>	
	<p>All x' are m</p> <hr style="border: 0.5px dashed black;"/> <p>All x' are m'</p>	
	<p>All m are x</p> <hr style="border: 0.5px dashed black;"/> <p>All m are x'</p>	
	<p>All m' are x</p> <hr style="border: 0.5px dashed black;"/> <p>All m' are x'</p>	

TABLE VIII.

<div style="border: 1px dashed black; padding: 5px; width: 100%;"> <table style="width: 100%; border-collapse: collapse;"> <tr> <td style="width: 50%; border-right: 1px dashed black; padding: 5px;"> <table style="width: 100%; border-collapse: collapse;"> <tr><td style="border-right: 1px dashed black; padding: 2px;">(0)</td><td style="padding: 2px;">---</td><td style="padding: 2px;">---</td></tr> <tr><td style="border-right: 1px dashed black; padding: 2px;">---</td><td style="padding: 2px;">(1)</td><td style="padding: 2px;">---</td></tr> <tr><td style="border-right: 1px dashed black; padding: 2px;">---</td><td style="padding: 2px;">---</td><td style="padding: 2px;">---</td></tr> <tr><td style="border-right: 1px dashed black; padding: 2px;">(0)</td><td style="padding: 2px;">---</td><td style="padding: 2px;">---</td></tr> </table> </td> <td style="width: 50%; padding: 5px;"> <p>All y are m</p> <hr style="border-top: 1px dashed black;"/> <p>All y are m'</p> </td> </tr> </table> </div>	<table style="width: 100%; border-collapse: collapse;"> <tr><td style="border-right: 1px dashed black; padding: 2px;">(0)</td><td style="padding: 2px;">---</td><td style="padding: 2px;">---</td></tr> <tr><td style="border-right: 1px dashed black; padding: 2px;">---</td><td style="padding: 2px;">(1)</td><td style="padding: 2px;">---</td></tr> <tr><td style="border-right: 1px dashed black; padding: 2px;">---</td><td style="padding: 2px;">---</td><td style="padding: 2px;">---</td></tr> <tr><td style="border-right: 1px dashed black; padding: 2px;">(0)</td><td style="padding: 2px;">---</td><td style="padding: 2px;">---</td></tr> </table>	(0)	---	---	---	(1)	---	---	---	---	(0)	---	---	<p>All y are m</p> <hr style="border-top: 1px dashed black;"/> <p>All y are m'</p>	<div style="border: 1px dashed black; padding: 5px; width: 100%;"> <table style="width: 100%; border-collapse: collapse;"> <tr> <td style="width: 50%; border-right: 1px dashed black; padding: 5px;"> <table style="width: 100%; border-collapse: collapse;"> <tr><td style="border-right: 1px dashed black; padding: 2px;">---</td><td style="padding: 2px;">---</td></tr> <tr><td style="border-right: 1px dashed black; padding: 2px;">(1)</td><td style="padding: 2px;">---</td></tr> <tr><td style="border-right: 1px dashed black; padding: 2px;">---</td><td style="padding: 2px;">---</td></tr> <tr><td style="border-right: 1px dashed black; padding: 2px;">---</td><td style="padding: 2px;">---</td></tr> </table> </td> <td style="width: 50%; padding: 5px;"> <p>All y are m</p> <hr style="border-top: 1px dashed black;"/> <p>All y' are m'</p> </td> </tr> </table> </div>	<table style="width: 100%; border-collapse: collapse;"> <tr><td style="border-right: 1px dashed black; padding: 2px;">---</td><td style="padding: 2px;">---</td></tr> <tr><td style="border-right: 1px dashed black; padding: 2px;">(1)</td><td style="padding: 2px;">---</td></tr> <tr><td style="border-right: 1px dashed black; padding: 2px;">---</td><td style="padding: 2px;">---</td></tr> <tr><td style="border-right: 1px dashed black; padding: 2px;">---</td><td style="padding: 2px;">---</td></tr> </table>	---	---	(1)	---	---	---	---	---	<p>All y are m</p> <hr style="border-top: 1px dashed black;"/> <p>All y' are m'</p>			
<table style="width: 100%; border-collapse: collapse;"> <tr><td style="border-right: 1px dashed black; padding: 2px;">(0)</td><td style="padding: 2px;">---</td><td style="padding: 2px;">---</td></tr> <tr><td style="border-right: 1px dashed black; padding: 2px;">---</td><td style="padding: 2px;">(1)</td><td style="padding: 2px;">---</td></tr> <tr><td style="border-right: 1px dashed black; padding: 2px;">---</td><td style="padding: 2px;">---</td><td style="padding: 2px;">---</td></tr> <tr><td style="border-right: 1px dashed black; padding: 2px;">(0)</td><td style="padding: 2px;">---</td><td style="padding: 2px;">---</td></tr> </table>	(0)	---	---	---	(1)	---	---	---	---	(0)	---	---	<p>All y are m</p> <hr style="border-top: 1px dashed black;"/> <p>All y are m'</p>															
(0)	---	---																										
---	(1)	---																										
---	---	---																										
(0)	---	---																										
<table style="width: 100%; border-collapse: collapse;"> <tr><td style="border-right: 1px dashed black; padding: 2px;">---</td><td style="padding: 2px;">---</td></tr> <tr><td style="border-right: 1px dashed black; padding: 2px;">(1)</td><td style="padding: 2px;">---</td></tr> <tr><td style="border-right: 1px dashed black; padding: 2px;">---</td><td style="padding: 2px;">---</td></tr> <tr><td style="border-right: 1px dashed black; padding: 2px;">---</td><td style="padding: 2px;">---</td></tr> </table>	---	---	(1)	---	---	---	---	---	<p>All y are m</p> <hr style="border-top: 1px dashed black;"/> <p>All y' are m'</p>																			
---	---																											
(1)	---																											
---	---																											
---	---																											
<div style="border: 1px dashed black; padding: 5px; width: 100%;"> <table style="width: 100%; border-collapse: collapse;"> <tr> <td style="width: 50%; border-right: 1px dashed black; padding: 5px;"> <table style="width: 100%; border-collapse: collapse;"> <tr><td style="border-right: 1px dashed black; padding: 2px;">---</td><td style="padding: 2px;">---</td><td style="padding: 2px;">(0)</td></tr> <tr><td style="border-right: 1px dashed black; padding: 2px;">---</td><td style="padding: 2px;">(1)</td><td style="padding: 2px;">---</td></tr> <tr><td style="border-right: 1px dashed black; padding: 2px;">---</td><td style="padding: 2px;">---</td><td style="padding: 2px;">---</td></tr> <tr><td style="border-right: 1px dashed black; padding: 2px;">---</td><td style="padding: 2px;">---</td><td style="padding: 2px;">(0)</td></tr> </table> </td> <td style="width: 50%; padding: 5px;"> <p>All y' are m</p> <hr style="border-top: 1px dashed black;"/> <p>All y' are m'</p> </td> </tr> </table> </div>	<table style="width: 100%; border-collapse: collapse;"> <tr><td style="border-right: 1px dashed black; padding: 2px;">---</td><td style="padding: 2px;">---</td><td style="padding: 2px;">(0)</td></tr> <tr><td style="border-right: 1px dashed black; padding: 2px;">---</td><td style="padding: 2px;">(1)</td><td style="padding: 2px;">---</td></tr> <tr><td style="border-right: 1px dashed black; padding: 2px;">---</td><td style="padding: 2px;">---</td><td style="padding: 2px;">---</td></tr> <tr><td style="border-right: 1px dashed black; padding: 2px;">---</td><td style="padding: 2px;">---</td><td style="padding: 2px;">(0)</td></tr> </table>	---	---	(0)	---	(1)	---	---	---	---	---	---	(0)	<p>All y' are m</p> <hr style="border-top: 1px dashed black;"/> <p>All y' are m'</p>	<div style="border: 1px dashed black; padding: 5px; width: 100%;"> <table style="width: 100%; border-collapse: collapse;"> <tr> <td style="width: 50%; border-right: 1px dashed black; padding: 5px;"> <table style="width: 100%; border-collapse: collapse;"> <tr><td style="border-right: 1px dashed black; padding: 2px;">---</td><td style="padding: 2px;">---</td></tr> <tr><td style="border-right: 1px dashed black; padding: 2px;">---</td><td style="padding: 2px;">(0)</td></tr> <tr><td style="border-right: 1px dashed black; padding: 2px;">---</td><td style="padding: 2px;">---</td></tr> <tr><td style="border-right: 1px dashed black; padding: 2px;">---</td><td style="padding: 2px;">(0)</td></tr> </table> </td> <td style="width: 50%; padding: 5px;"> <p>All y' are m</p> <hr style="border-top: 1px dashed black;"/> <p>All y' are m'</p> </td> </tr> </table> </div>	<table style="width: 100%; border-collapse: collapse;"> <tr><td style="border-right: 1px dashed black; padding: 2px;">---</td><td style="padding: 2px;">---</td></tr> <tr><td style="border-right: 1px dashed black; padding: 2px;">---</td><td style="padding: 2px;">(0)</td></tr> <tr><td style="border-right: 1px dashed black; padding: 2px;">---</td><td style="padding: 2px;">---</td></tr> <tr><td style="border-right: 1px dashed black; padding: 2px;">---</td><td style="padding: 2px;">(0)</td></tr> </table>	---	---	---	(0)	---	---	---	(0)	<p>All y' are m</p> <hr style="border-top: 1px dashed black;"/> <p>All y' are m'</p>			
<table style="width: 100%; border-collapse: collapse;"> <tr><td style="border-right: 1px dashed black; padding: 2px;">---</td><td style="padding: 2px;">---</td><td style="padding: 2px;">(0)</td></tr> <tr><td style="border-right: 1px dashed black; padding: 2px;">---</td><td style="padding: 2px;">(1)</td><td style="padding: 2px;">---</td></tr> <tr><td style="border-right: 1px dashed black; padding: 2px;">---</td><td style="padding: 2px;">---</td><td style="padding: 2px;">---</td></tr> <tr><td style="border-right: 1px dashed black; padding: 2px;">---</td><td style="padding: 2px;">---</td><td style="padding: 2px;">(0)</td></tr> </table>	---	---	(0)	---	(1)	---	---	---	---	---	---	(0)	<p>All y' are m</p> <hr style="border-top: 1px dashed black;"/> <p>All y' are m'</p>															
---	---	(0)																										
---	(1)	---																										
---	---	---																										
---	---	(0)																										
<table style="width: 100%; border-collapse: collapse;"> <tr><td style="border-right: 1px dashed black; padding: 2px;">---</td><td style="padding: 2px;">---</td></tr> <tr><td style="border-right: 1px dashed black; padding: 2px;">---</td><td style="padding: 2px;">(0)</td></tr> <tr><td style="border-right: 1px dashed black; padding: 2px;">---</td><td style="padding: 2px;">---</td></tr> <tr><td style="border-right: 1px dashed black; padding: 2px;">---</td><td style="padding: 2px;">(0)</td></tr> </table>	---	---	---	(0)	---	---	---	(0)	<p>All y' are m</p> <hr style="border-top: 1px dashed black;"/> <p>All y' are m'</p>																			
---	---																											
---	(0)																											
---	---																											
---	(0)																											
<div style="border: 1px dashed black; padding: 5px; width: 100%;"> <table style="width: 100%; border-collapse: collapse;"> <tr> <td style="width: 50%; border-right: 1px dashed black; padding: 5px;"> <table style="width: 100%; border-collapse: collapse;"> <tr><td style="border-right: 1px dashed black; padding: 2px;">---</td><td style="padding: 2px;">---</td><td style="padding: 2px;">(0)</td></tr> <tr><td style="border-right: 1px dashed black; padding: 2px;">---</td><td style="padding: 2px;">(1)</td><td style="padding: 2px;">---</td></tr> <tr><td style="border-right: 1px dashed black; padding: 2px;">---</td><td style="padding: 2px;">---</td><td style="padding: 2px;">---</td></tr> <tr><td style="border-right: 1px dashed black; padding: 2px;">---</td><td style="padding: 2px;">---</td><td style="padding: 2px;">(0)</td></tr> </table> </td> <td style="width: 50%; padding: 5px;"> <p>All m are y</p> <hr style="border-top: 1px dashed black;"/> <p>All m are y'</p> </td> </tr> </table> </div>	<table style="width: 100%; border-collapse: collapse;"> <tr><td style="border-right: 1px dashed black; padding: 2px;">---</td><td style="padding: 2px;">---</td><td style="padding: 2px;">(0)</td></tr> <tr><td style="border-right: 1px dashed black; padding: 2px;">---</td><td style="padding: 2px;">(1)</td><td style="padding: 2px;">---</td></tr> <tr><td style="border-right: 1px dashed black; padding: 2px;">---</td><td style="padding: 2px;">---</td><td style="padding: 2px;">---</td></tr> <tr><td style="border-right: 1px dashed black; padding: 2px;">---</td><td style="padding: 2px;">---</td><td style="padding: 2px;">(0)</td></tr> </table>	---	---	(0)	---	(1)	---	---	---	---	---	---	(0)	<p>All m are y</p> <hr style="border-top: 1px dashed black;"/> <p>All m are y'</p>	<div style="border: 1px dashed black; padding: 5px; width: 100%;"> <table style="width: 100%; border-collapse: collapse;"> <tr> <td style="width: 50%; border-right: 1px dashed black; padding: 5px;"> <table style="width: 100%; border-collapse: collapse;"> <tr><td style="border-right: 1px dashed black; padding: 2px;">---</td><td style="padding: 2px;">---</td></tr> <tr><td style="border-right: 1px dashed black; padding: 2px;">(0)</td><td style="padding: 2px;">---</td></tr> <tr><td style="border-right: 1px dashed black; padding: 2px;">---</td><td style="padding: 2px;">(1)</td></tr> <tr><td style="border-right: 1px dashed black; padding: 2px;">---</td><td style="padding: 2px;">---</td></tr> </table> </td> <td style="width: 50%; padding: 5px;"> <p>All m are y</p> <hr style="border-top: 1px dashed black;"/> <p>All m are y'</p> </td> </tr> </table> </div>	<table style="width: 100%; border-collapse: collapse;"> <tr><td style="border-right: 1px dashed black; padding: 2px;">---</td><td style="padding: 2px;">---</td></tr> <tr><td style="border-right: 1px dashed black; padding: 2px;">(0)</td><td style="padding: 2px;">---</td></tr> <tr><td style="border-right: 1px dashed black; padding: 2px;">---</td><td style="padding: 2px;">(1)</td></tr> <tr><td style="border-right: 1px dashed black; padding: 2px;">---</td><td style="padding: 2px;">---</td></tr> </table>	---	---	(0)	---	---	(1)	---	---	<p>All m are y</p> <hr style="border-top: 1px dashed black;"/> <p>All m are y'</p>			
<table style="width: 100%; border-collapse: collapse;"> <tr><td style="border-right: 1px dashed black; padding: 2px;">---</td><td style="padding: 2px;">---</td><td style="padding: 2px;">(0)</td></tr> <tr><td style="border-right: 1px dashed black; padding: 2px;">---</td><td style="padding: 2px;">(1)</td><td style="padding: 2px;">---</td></tr> <tr><td style="border-right: 1px dashed black; padding: 2px;">---</td><td style="padding: 2px;">---</td><td style="padding: 2px;">---</td></tr> <tr><td style="border-right: 1px dashed black; padding: 2px;">---</td><td style="padding: 2px;">---</td><td style="padding: 2px;">(0)</td></tr> </table>	---	---	(0)	---	(1)	---	---	---	---	---	---	(0)	<p>All m are y</p> <hr style="border-top: 1px dashed black;"/> <p>All m are y'</p>															
---	---	(0)																										
---	(1)	---																										
---	---	---																										
---	---	(0)																										
<table style="width: 100%; border-collapse: collapse;"> <tr><td style="border-right: 1px dashed black; padding: 2px;">---</td><td style="padding: 2px;">---</td></tr> <tr><td style="border-right: 1px dashed black; padding: 2px;">(0)</td><td style="padding: 2px;">---</td></tr> <tr><td style="border-right: 1px dashed black; padding: 2px;">---</td><td style="padding: 2px;">(1)</td></tr> <tr><td style="border-right: 1px dashed black; padding: 2px;">---</td><td style="padding: 2px;">---</td></tr> </table>	---	---	(0)	---	---	(1)	---	---	<p>All m are y</p> <hr style="border-top: 1px dashed black;"/> <p>All m are y'</p>																			
---	---																											
(0)	---																											
---	(1)																											
---	---																											
<div style="border: 1px dashed black; padding: 5px; width: 100%;"> <table style="width: 100%; border-collapse: collapse;"> <tr> <td style="width: 50%; border-right: 1px dashed black; padding: 5px;"> <table style="width: 100%; border-collapse: collapse;"> <tr><td style="border-right: 1px dashed black; padding: 2px;">---</td><td style="padding: 2px;">---</td><td style="padding: 2px;">(0)</td></tr> <tr><td style="border-right: 1px dashed black; padding: 2px;">---</td><td style="padding: 2px;">---</td><td style="padding: 2px;">---</td></tr> <tr><td style="border-right: 1px dashed black; padding: 2px;">(1)</td><td style="padding: 2px;">---</td><td style="padding: 2px;">---</td></tr> <tr><td style="border-right: 1px dashed black; padding: 2px;">---</td><td style="padding: 2px;">---</td><td style="padding: 2px;">---</td></tr> <tr><td style="border-right: 1px dashed black; padding: 2px;">---</td><td style="padding: 2px;">---</td><td style="padding: 2px;">(0)</td></tr> </table> </td> <td style="width: 50%; padding: 5px;"> <p>All m' are y</p> <hr style="border-top: 1px dashed black;"/> <p>All m' are y'</p> </td> </tr> </table> </div>	<table style="width: 100%; border-collapse: collapse;"> <tr><td style="border-right: 1px dashed black; padding: 2px;">---</td><td style="padding: 2px;">---</td><td style="padding: 2px;">(0)</td></tr> <tr><td style="border-right: 1px dashed black; padding: 2px;">---</td><td style="padding: 2px;">---</td><td style="padding: 2px;">---</td></tr> <tr><td style="border-right: 1px dashed black; padding: 2px;">(1)</td><td style="padding: 2px;">---</td><td style="padding: 2px;">---</td></tr> <tr><td style="border-right: 1px dashed black; padding: 2px;">---</td><td style="padding: 2px;">---</td><td style="padding: 2px;">---</td></tr> <tr><td style="border-right: 1px dashed black; padding: 2px;">---</td><td style="padding: 2px;">---</td><td style="padding: 2px;">(0)</td></tr> </table>	---	---	(0)	---	---	---	(1)	---	---	---	---	---	---	---	(0)	<p>All m' are y</p> <hr style="border-top: 1px dashed black;"/> <p>All m' are y'</p>	<div style="border: 1px dashed black; padding: 5px; width: 100%;"> <table style="width: 100%; border-collapse: collapse;"> <tr> <td style="width: 50%; border-right: 1px dashed black; padding: 5px;"> <table style="width: 100%; border-collapse: collapse;"> <tr><td style="border-right: 1px dashed black; padding: 2px;">---</td><td style="padding: 2px;">---</td></tr> <tr><td style="border-right: 1px dashed black; padding: 2px;">---</td><td style="padding: 2px;">---</td></tr> <tr><td style="border-right: 1px dashed black; padding: 2px;">---</td><td style="padding: 2px;">---</td></tr> <tr><td style="border-right: 1px dashed black; padding: 2px;">---</td><td style="padding: 2px;">---</td></tr> </table> </td> <td style="width: 50%; padding: 5px;"> <p>All m' are y</p> <hr style="border-top: 1px dashed black;"/> <p>All m' are y'</p> </td> </tr> </table> </div>	<table style="width: 100%; border-collapse: collapse;"> <tr><td style="border-right: 1px dashed black; padding: 2px;">---</td><td style="padding: 2px;">---</td></tr> <tr><td style="border-right: 1px dashed black; padding: 2px;">---</td><td style="padding: 2px;">---</td></tr> <tr><td style="border-right: 1px dashed black; padding: 2px;">---</td><td style="padding: 2px;">---</td></tr> <tr><td style="border-right: 1px dashed black; padding: 2px;">---</td><td style="padding: 2px;">---</td></tr> </table>	---	---	---	---	---	---	---	---	<p>All m' are y</p> <hr style="border-top: 1px dashed black;"/> <p>All m' are y'</p>
<table style="width: 100%; border-collapse: collapse;"> <tr><td style="border-right: 1px dashed black; padding: 2px;">---</td><td style="padding: 2px;">---</td><td style="padding: 2px;">(0)</td></tr> <tr><td style="border-right: 1px dashed black; padding: 2px;">---</td><td style="padding: 2px;">---</td><td style="padding: 2px;">---</td></tr> <tr><td style="border-right: 1px dashed black; padding: 2px;">(1)</td><td style="padding: 2px;">---</td><td style="padding: 2px;">---</td></tr> <tr><td style="border-right: 1px dashed black; padding: 2px;">---</td><td style="padding: 2px;">---</td><td style="padding: 2px;">---</td></tr> <tr><td style="border-right: 1px dashed black; padding: 2px;">---</td><td style="padding: 2px;">---</td><td style="padding: 2px;">(0)</td></tr> </table>	---	---	(0)	---	---	---	(1)	---	---	---	---	---	---	---	(0)	<p>All m' are y</p> <hr style="border-top: 1px dashed black;"/> <p>All m' are y'</p>												
---	---	(0)																										
---	---	---																										
(1)	---	---																										
---	---	---																										
---	---	(0)																										
<table style="width: 100%; border-collapse: collapse;"> <tr><td style="border-right: 1px dashed black; padding: 2px;">---</td><td style="padding: 2px;">---</td></tr> <tr><td style="border-right: 1px dashed black; padding: 2px;">---</td><td style="padding: 2px;">---</td></tr> <tr><td style="border-right: 1px dashed black; padding: 2px;">---</td><td style="padding: 2px;">---</td></tr> <tr><td style="border-right: 1px dashed black; padding: 2px;">---</td><td style="padding: 2px;">---</td></tr> </table>	---	---	---	---	---	---	---	---	<p>All m' are y</p> <hr style="border-top: 1px dashed black;"/> <p>All m' are y'</p>																			
---	---																											
---	---																											
---	---																											
---	---																											